

CATALOGO GENERALE 10/21

Cisterne in Vetroresina e Polietilene



AGRICOLTURA

VETRORESINA FIBERGLASS



SERIE GALAXI SR

AUTOPORTANTI CON SEDILE
E SCASSO RUOTE

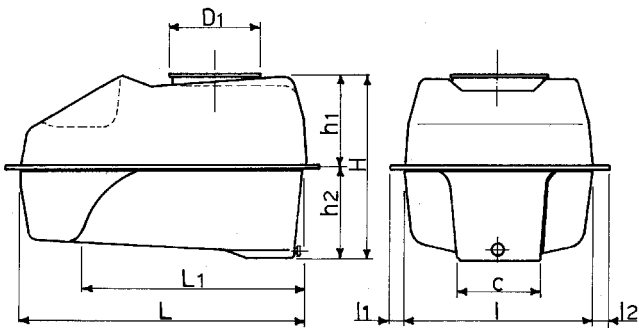

Art.	Cap. Lit.	L	L ₁	H	h ₁	h ₂	I	I ₁	C	D ₁
1048	200	1045	830	655	265	390	630	45	260	310
1049	300	1045	830	810	420	390	630	45	260	310
1050	400	1200	*620	840	420	420	655	45	300	310

* SR 400 L₁ = Scasso ruota centrale

SERIE MARTE

AUTOPORTANTI CON
SUPPORTO CENTRALE

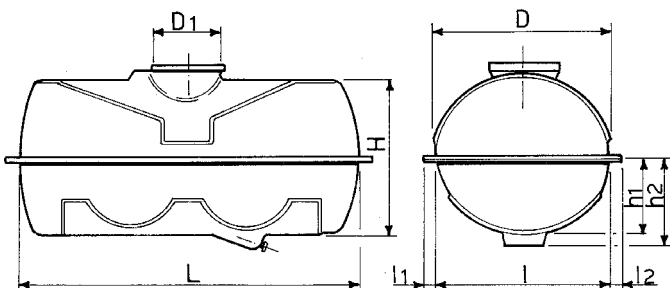

Art.	Cap. Lit.	L	H	D	I	I _{1,2}	h ₁	h ₂	D ₁
1036	1000	1800	830	900	900	50	410	490	415

SERIE SUPERMARTE



AUTOPORTANTI PER
TRASPORTO, STOCCAGGIO
E CONCIMI LIQUIDI

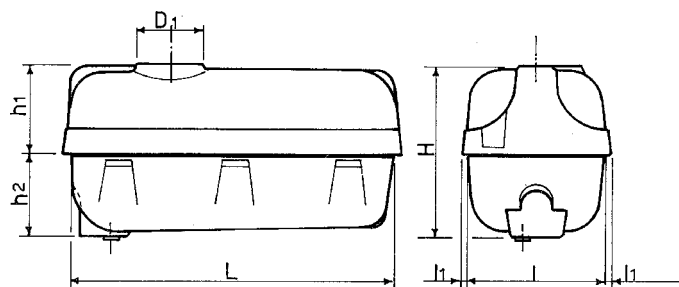

Art.	Cap. Lit.	L	H	h ₁	h ₂	I	I ₁	D ₁
1037	1000	1795	950	490	460	775	60	415
1076	1200	1795	1100	640	460	775	60	415
1038	1500	1990	1050	540	510	940	60	415
1039	2000	1990	1300	700	600	940	60	415
1040	*3000	2580	1410	730	680	1050	60	415
1041	*4000	2580	1690	1010	680	1050	60	415

* PARATIA FRANGIFLUTTO IN DOTAZIONE

SERIE NAUTILUS



RETTANGOLARI PER PIANALI

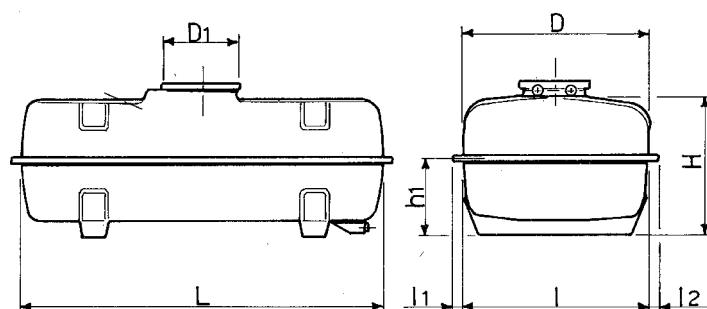

Art.	Cap. Lit.	L	H	D	I	I _{1,2}	h ₁	D ₁
1058	400	1240	520	840	840	30	305	310
1059	600	1260	635	985	985	30	355	310
1060	800	1405	665	1080	1080	40	355	415
1061	1000	1700	670	1120	1120	30	375	415



RETTANGOLARE PER PIANALI
CON SCASSO RUOTE

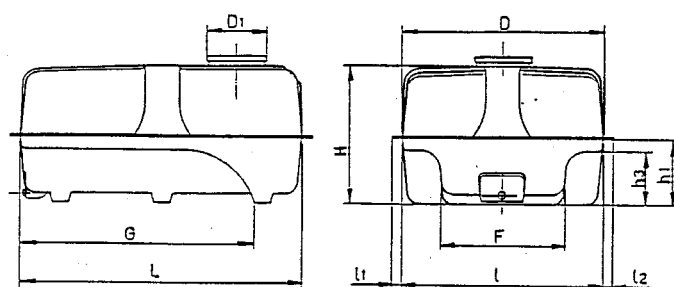

Art.	Cap. lt.	L	H	D	I	I _{1,2}	G	F	h ₁	h ₃	D ₁
1062	2000	1950	950	1400	1400	75	1630	930	460	380	415

SERIE NAUTILUS RIALZO

RETTANGOLARI PER PIANALI CON RIALZO CENTRALE

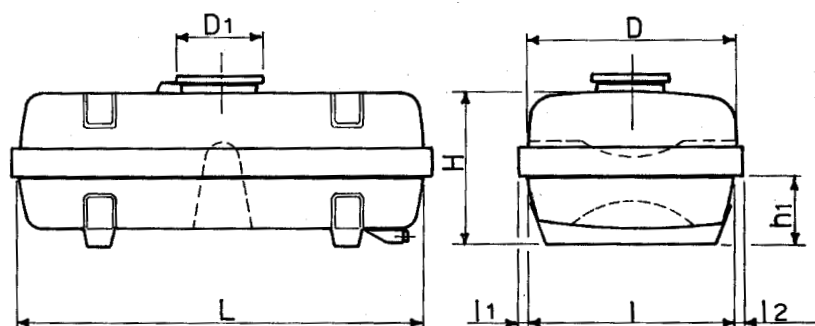

Art.	Cap. Lit.	L	H	I	I _{1,2}	h ₁	D	D ₁
1054	800	1260	790	985	30	355	985	310
1055	1500	1700	935	1120	30	375	1120	415
1056	*2000	1700	1240	1120	30	375	1120	415

* PARATIA FRANGIFLUTTO IN DOTAZIONE

RETTANGOLARE PER PIANALI CON RIALZO CENTRALE E SCASSO RUOTE

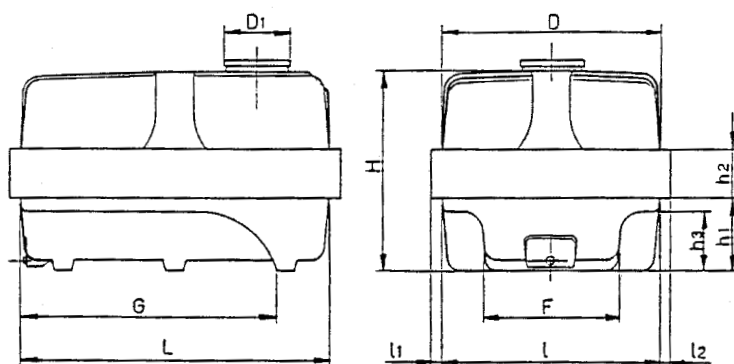

Art.	Cap. lt.	L	H	D	I	I _{1,2}	G	F	h ₁	h ₂	h ₃	D ₁
1057	3000	1950	1265	1400	1400	75	1630	930	460	315	380	415

PARATIA FRANGIFLUTTO IN DOTAZIONE.

SERIE NADIR TR CON LAVAMANI



ATOMIZZATORI TRAINATI "A BASSO VOLUME"

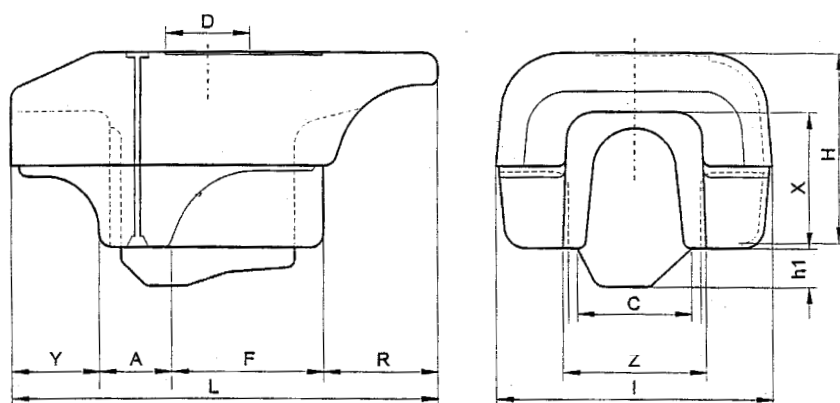

Art.	Cap. lt.	L	H	I	X	Y	Z	D	C	R	F	h ₁	A
1131	1000	192	870	1165	60	365	585	415	340	550	690	17	440

EUROCOMPACT TR



ATOMIZZATORI TRAINATI CON COFANO POSTERIORE, CISTERNE LAVAMANI E LAVAIMPIANTO

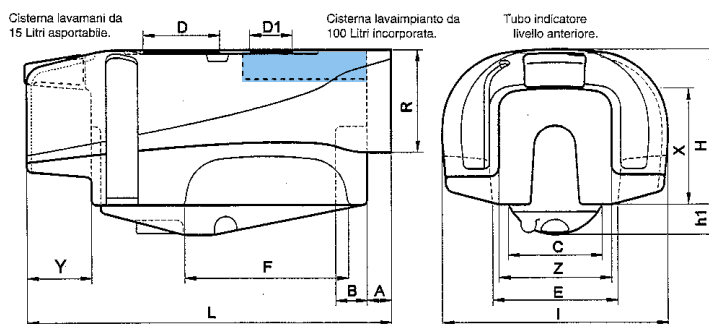

PROGETTATA PER NORMATIVE 

Art.	Cap. lt.	L	H	I	X	Y	Z	D	D ₁	C	E	R	F	h ₁	A	B
1135	600	1620	820	1010	580	340	540	415	210	400	615	450	720	70	100	120
1136	800	1830	830	1080	580	320	570	415	210	480	600	450	720	90	100	170
1137	1000	1950	830	1200	600	360	580	415	210	520	670	550	880	160	130	170
1138	1500	2220	900	1300	660	360	590	415	210	600	740	580	920	160	130	170
1139	2000	2485	1000	1395	690	360	590	415	210	650	850	580	1060	160	130	170

EUROCOMPACT TR JUNIOR



ATOMIZZATORI TRAINATI CON COFANO POSTERIORE E CISTERNA LAVAMANI

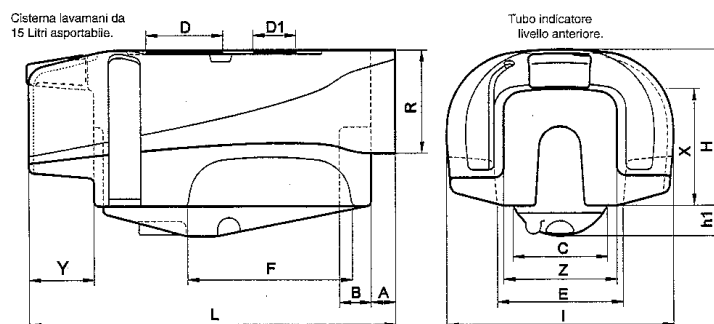

Art.	Cap. lt.	L	H	I	X	Y	Z	D	D ₁	C	E	R	F	h ₁	A	B
1145	600	1620	820	1010	580	340	540	415	210	400	615	450	720	70	100	120
1146	800	1830	830	1080	580	320	570	415	210	480	600	450	720	90	100	170
1147	1000	1950	830	1200	600	360	580	415	210	520	670	550	880	160	130	170
1148	1500	2220	900	1300	660	360	590	415	210	600	740	580	920	160	130	170
1149	2000	2485	1000	1395	690	360	590	415	210	650	850	580	1060	160	130	170

EUROMIRAGE TR



PROGETTATA
PER NORMATIVE **CE**

ATOMIZZATORI TRAINATI CON COFANO POSTERIORE, CISTERNE LAVAMANI E LAVAIMPIANTO

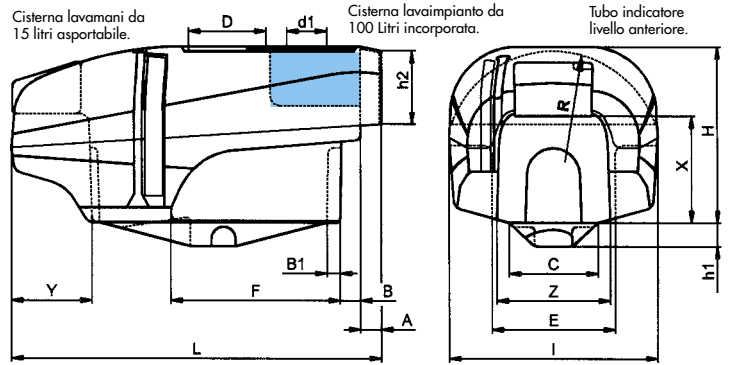

Art.	Cap. lt.	L	H	I	X	Y	Z	D	d ₁	C	E	R	F	h ₁	h ₂	A	B	B ₁
1161	600	1625	790	1000	420	330	590	415	210	420	540	465	780	100	360	100	100	80
1162	800	1830	880	1045	570	365	590	415	210	430	540	465	890	100	385	100	90	135
1163	1000	1940	880	1150	580	365	600	415	210	470	620	575	920	100	330	110	110	70
1164	1500	2200	990	1320	690	370	600	415	210	570	720	585	1020	120	435	80	100	85
1165	2000	2490	1060	1380	720	370	600	415	210	570	760	595	1120	120	435	80	110	85

EUROMIRAGE TR JUNIOR



ATOMIZZATORI TRAINATI CON COFANO POSTERIORE E CISTERNA LAVAMANI

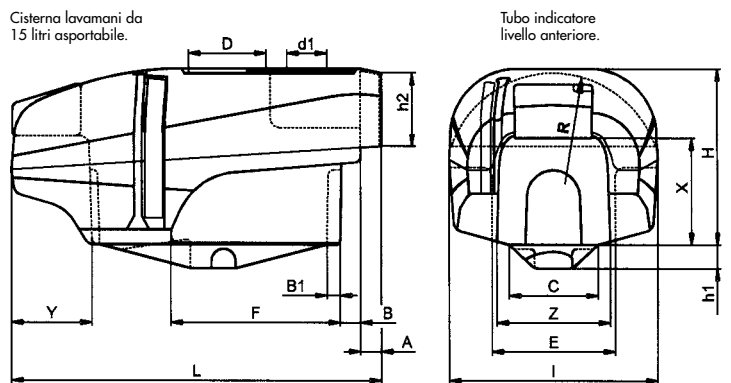

Art.	Cap. lt.	L	H	I	X	Y	Z	D	d ₁	C	E	R	F	h ₁	h ₂	A	B	B ₁
1166	600	1625	790	1000	420	330	590	415	210	420	540	465	780	100	360	100	100	80
1167	800	1830	880	1045	570	365	590	415	210	430	540	465	890	100	385	100	90	135
1168	1000	1940	880	1150	580	365	600	415	210	470	620	575	920	100	330	110	110	70
1169	1500	2200	990	1320	690	370	600	415	210	570	720	585	1020	120	435	80	100	85
1170	2000	2490	1060	1380	720	370	600	415	210	570	760	595	1120	120	435	80	110	85

POLIETILENE

POLYETHYLENE



SERIE POLIGOOD TANK

SERBATOI
MULTIUSO

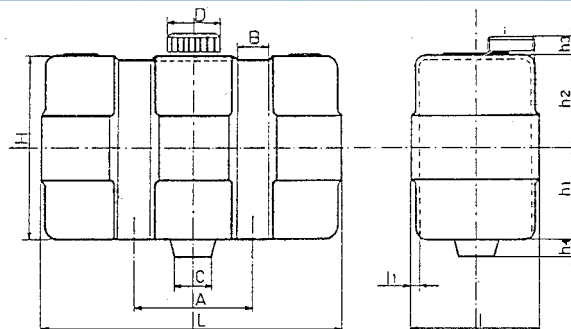

TANK 10

Art.	Cap. lt.	L	I	A	I ₁	H	B	h ₁	h ₂	h ₃	h ₄	C	D
1546	10	380	160	150	10	230	40	115	115	25	15	55	60

La TANK 10 è anche nella versione senza pozzetto di scarico centrale.

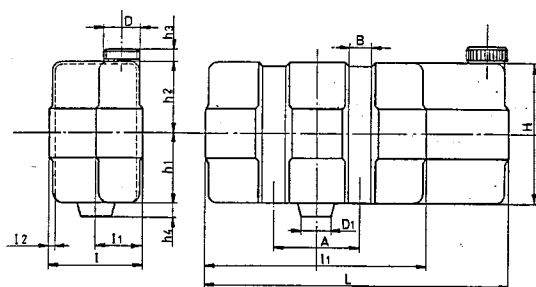

TANK 13

Art.	Cap. lt.	L	I	H	L ₁	I ₁	I ₂	h ₁	h ₂	h ₃	h ₄	A	B	D	D ₁
1547	13	520	160	230	380	80	10	115	115	25	15	150	40	60	55

La TANK 13 è anche nella versione senza pozzetto di scarico centrale.

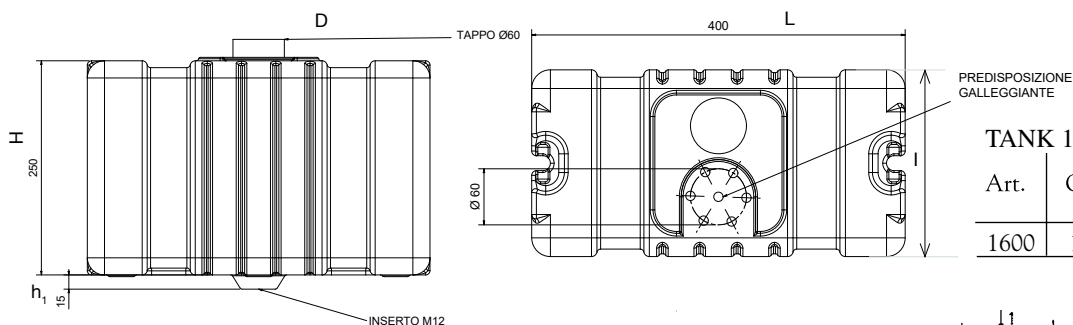

TANK 15

Art.	Cap. lt.	L	H	I	h ₁	D
1600	15	400	250	200	15	60

TANK 20

Art.	Cap. lt.	L	I	H	D	h ₁	h ₂	h ₃	I ₁	I ₂	α
1548	20	480	300	165	60	115	50	65	136	30	45°

SERIE POLIGOOD TANK

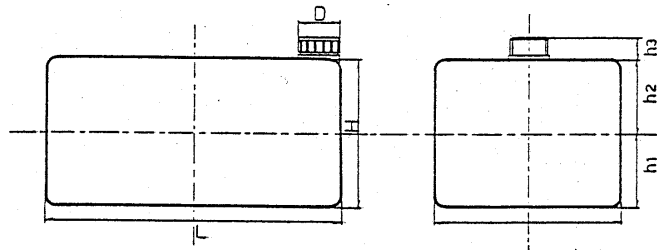

TANK 30-40-50

Art.	Cap. Lit.	L	I	H	D	h ₁	h ₂	h ₃
1549	30	480	300	230	60	115	115	25
1550	40	480	300	310	60	115	195	25
1551	50	480	300	360	60	115	245	25

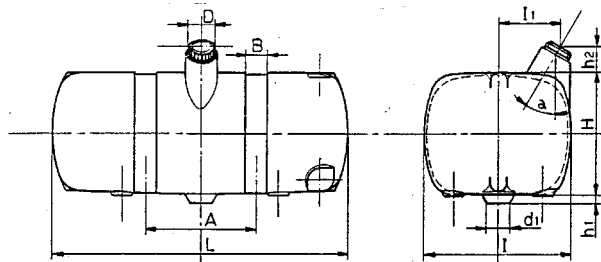

TANK K 30-45

Art.	Cap. Lit.	L	I	H	D	h ₁	h ₂	I ₁	d ₁	A	B	α
1552	30	520	330	230	60	15	20	95	50	250	50	0°
1553	45	660	330	270	60	15	60	140	50	250	50	30°

La serie K è anche nella versione senza pozzetto di scarico centrale.

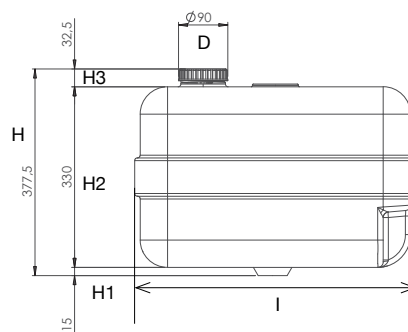
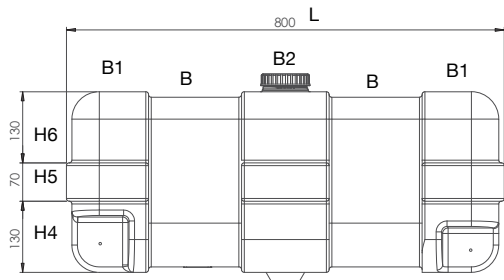

TANK K 100

Art.	Cap. Lit.	L	I	H	H ₁	H ₂	H ₃
1601	100	800	514	377	15	330	32

H ₄	H ₅	H ₆	D	B	B ₁	B ₂
130	70	130	90	170	150	160

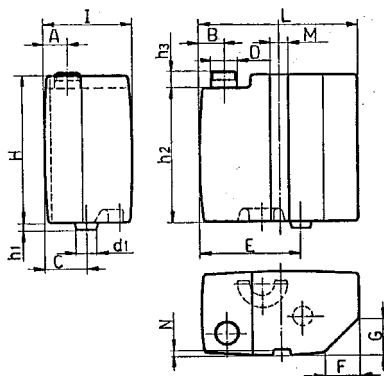

TANK VR 20

Art.	Cap. Lit.	L	I	H	h ₁	h ₂	h ₃	A
1554	20	380	210	360	15	330	40	55

B	C	E	F	G	M	N	d ₁	D
60	95	240	85	90	40	12	50	60

La serie VR 20 è anche nella versione senza pozzetto di scarico.

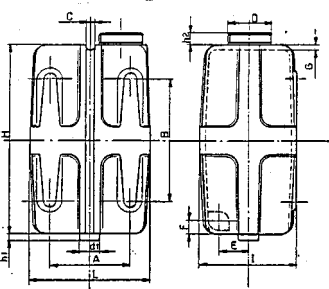

TANK VR 30

Art.	Cap.	L	I	H	h ₁	h ₂
1555	30	300	240	490	15	25

A	B	C	G	E	F	d ₁	D•
200	320	25	12,5	70	35	50	60

La serie VR 30 è anche nella versione senza pozzetto di scarico centrale.

• in alternativa D = 80, D = 110

SERIE POLY

CISTERNE MULTIUSO

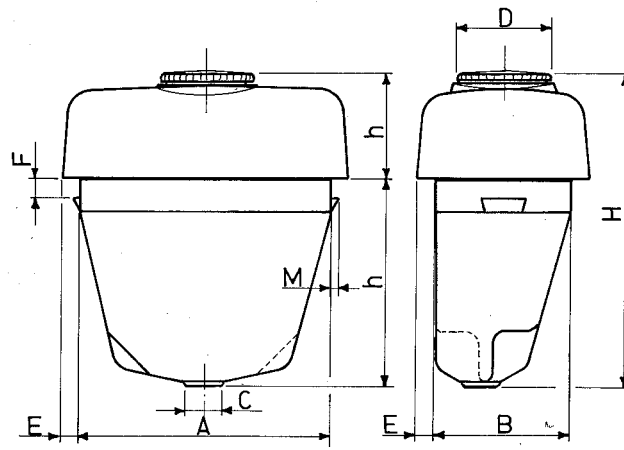

POLY 85

Art.	Cap. lt.	A	B	C	E	F	M	H	h ₁	h ₂	D
1545	85	550	300	80	40	40	15	680	450	230	200

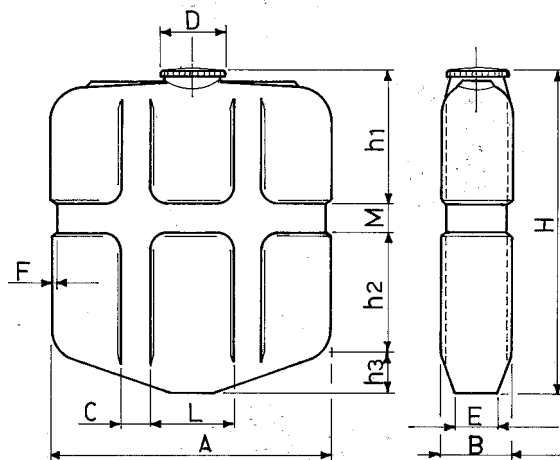

POLY 30

Art.	Cap. lt.	A	B	C	L	E	F	D	M	H	h ₁	h ₂	h ₃
1543	30	500	130	50	150	80	10	110	50	580	250	210	70

SERIE POLY

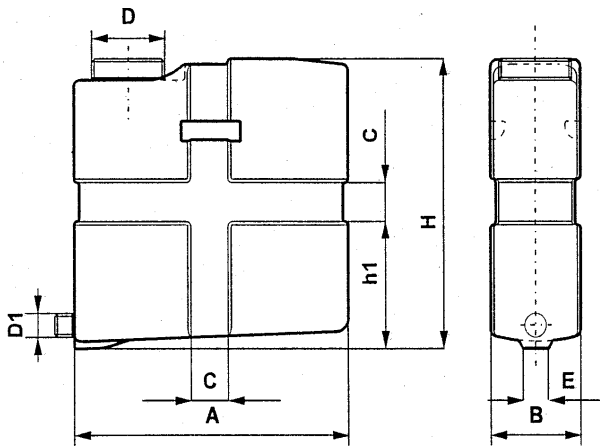

POLY 15

Art.	Cap. Lit.	A	B	C	D	D ₁	E	H	h ₁
1565	15	420	135	50	110	32	35	400	175

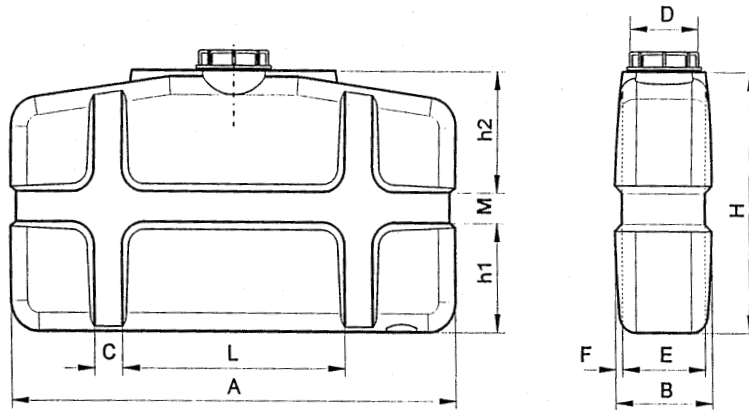

POLY 50

Art.	Cap. lt.	A	B	C	D	E	F	H	h ₁	h ₂	L	M
1544	50	800	170	60	120	150	10	420	160	200	400	60

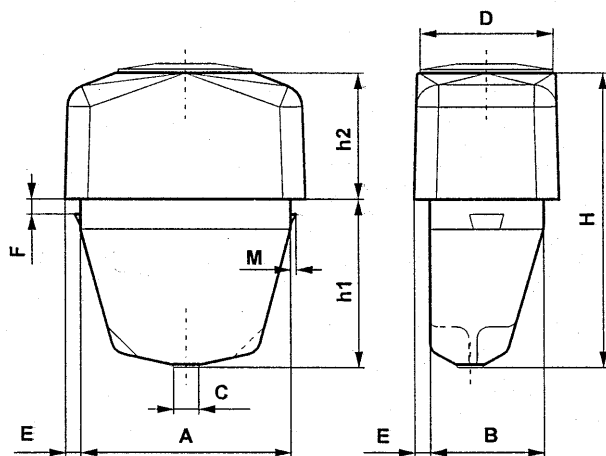

POLY 105

Art.	Cap. lt.	A	B	C	E	F	M	H	h ₁	h ₂	D
1564	105	550	300	80	40	40	15	780	450	330	310

SERIE POLIGOOD CR

CARRIOLA

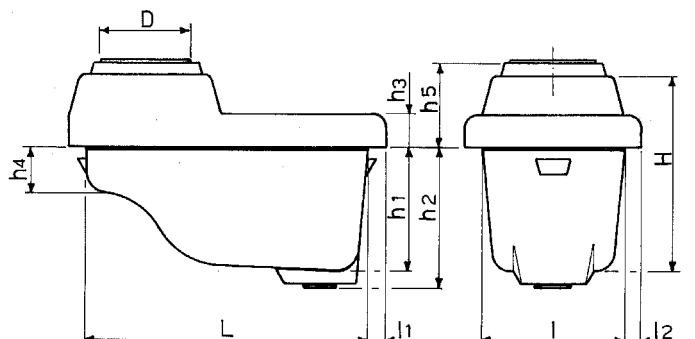

Art.	Cap. lt.	L	I	H	I _{1,2}	h ₁	h ₂	h ₃	h ₄	h ₅	D
1524	70	730	380	410	30	285	325	60	100	150	200
1525	70	Versione GIRATA: con la parte superiore invertita per il montaggio della pompa a mano									
1526	75	720	390	415	30	285	320	60	120	155	200

SERIE POLIGOOD SP



AUTOPORTANTI CON SUPPORTO PERIMETRALE

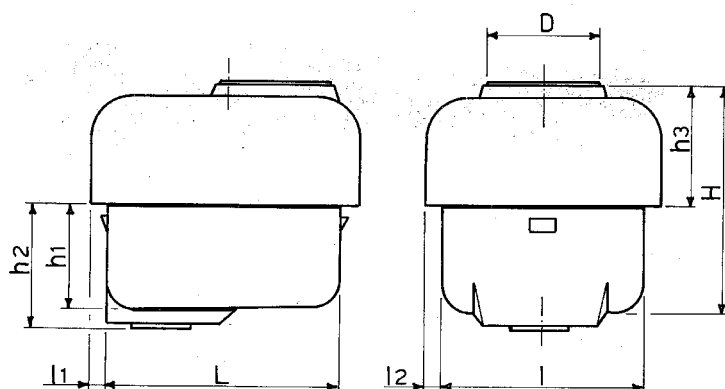

Art.	Cap. Lit.	L	I	H	I _{1,2}	h ₁	h ₂	h ₃	D
1527	50	400	370	360	30	175	205	215	200
1528	100	510	460	500	40	230	270	300	200

SERIE POLIGOOD SP

AUTOPORTANTI CON SUPPORTO PERIMETRALE

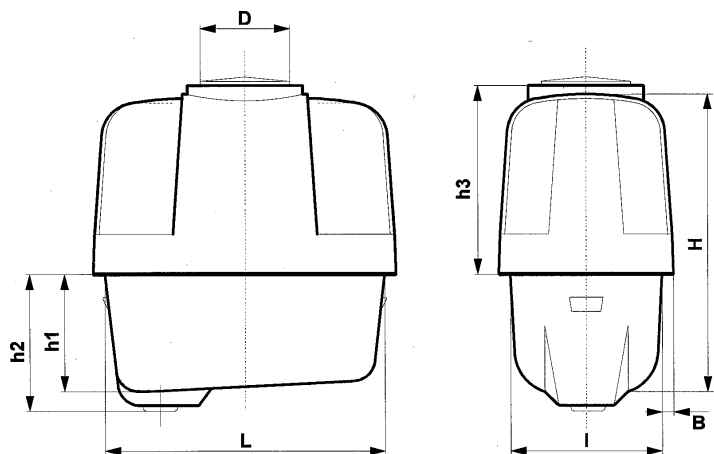

Art.	Cap. Lit.	L	I	H	B	h ₁	h ₂	h ₃	D
1529	200	860	480	550	40	275	320	315	210
1530	300	970	525	760	40	430	490	370	310
1531	400	970	525	1015	40	430	490	625	310

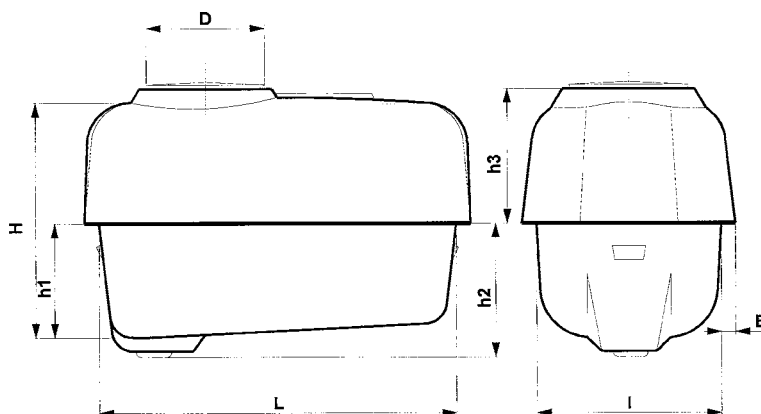

Art.	Cap. Lit.	L	I	H	B	h ₁	h ₂	h ₃	D
1532	500	1240	645	780	50	425	480	395	310
1533	600	1240	645	890	50	425	480	505	310

CON COPERCHIO DECENTRATO

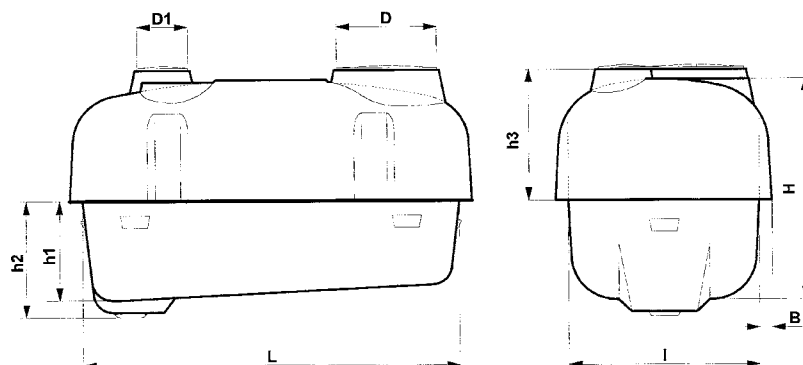

Art.	Cap. lt.	L	I	H	B	h ₁	h ₂	h ₃	D	D ₁
1534	800	1490	740	870	50	410	460	490	415	210
1535	1000	1490	740	1015	50	410	460	635	415	210

CON COPERCHIO Ø 210 SUPPLEMENTARE

SERIE POLIGOOD SP "NEW" 100



**PER CARRELLI DA IRRORAZIONE,
DISINFESTAZIONE E GIARDINAGGIO**

LA CISTERNA È COMPLETA DI:

- COPERCHIO A VITE
- SERBATOIO LAVAMANI CON RUBINETTO
- TAPPO DI SCARICO

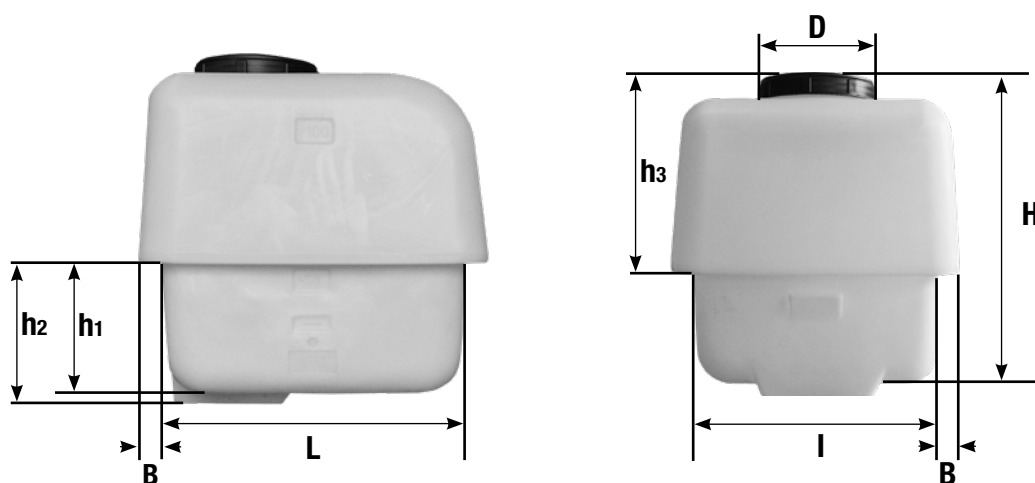

ART.	CAP. LT.	L	I	H	B	h ₁	h ₂	h ₃	D
1500	120	510	460	615	40	225	260	390	240
1581	10	SERBATOIO LAVAMANI							

SERIE POLIGOOD SP "NEW" 200



**PER CARRELLI DA IRRORAZIONE,
DISINFESTAZIONE E GIARDINAGGIO**

- LA CISTERNA È COMPLETA DI:**
- SERBATOIO LAVAMANI CON RUBINETTO
 - TAPPO DI SCARICO

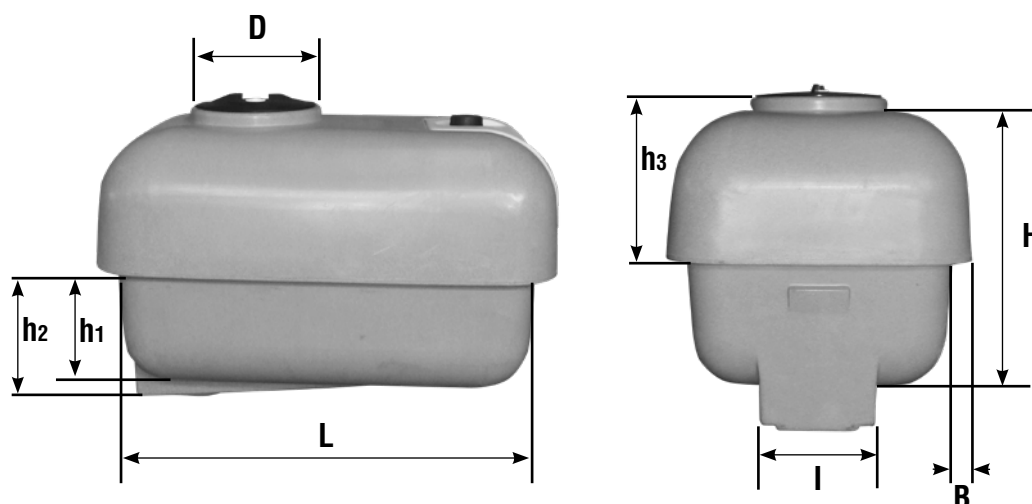

ART.	CAP. LT.	L	I	H	B	h1	h2	h3	D
1526	200	860	480	550	40	275	325	305	210
1581	10	SERBATOIO LAVAMANI							

SERIE POLIGOOD SP VP

AUTOPORTANTI A SVUOTAMENTO CENTRALE E VANO POMPA

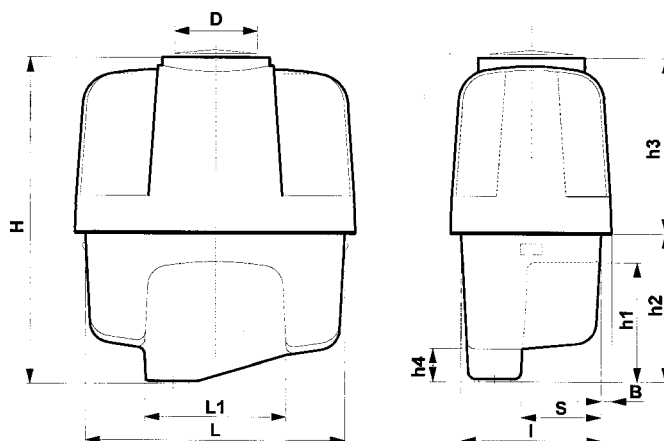

Art.	Cap. lt.	L	I	H	B	L ₁	h ₁	h ₂	h ₃	h ₄	S	D
1518	300	970	525	970	40	530	450	560	410	125	300	310
1519	400	970	525	1160	40	530	450	560	600	125	300	310

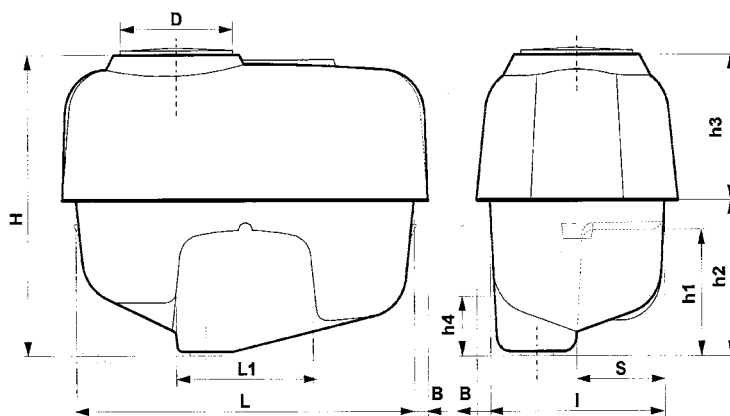

Art.	Cap. lt.	L	I	H	B	L ₁	h ₁	h ₂	h ₃	h ₄	S	D
1520	500	1240	645	950	50	540	420	520	430	130	300	310
1521	600	1240	645	1085	50	540	420	520	565	130	300	310

CON COPERCHIO DECENTRATO

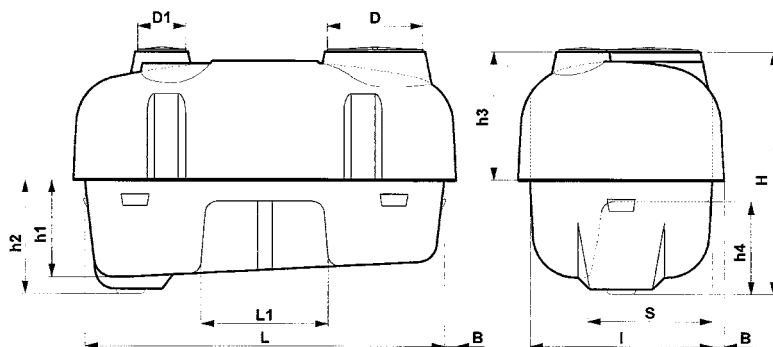

Art.	Cap. lt.	L	I	H	B	L ₁	h ₁	h ₂	h ₃	h ₄	S	D	D ₁
1522	800	1490	740	1000	50	550	460	510	490	410	450	415	210
1523	1000	1490	740	1145	50	550	460	510	635	410	450	415	210

CON COPERCHIO Ø 210 SUPPLEMENTARE

SERIE POLYPRISMA

AUTOPORTANTI A SVUOTAMENTO CENTRALE E VANO POMPA

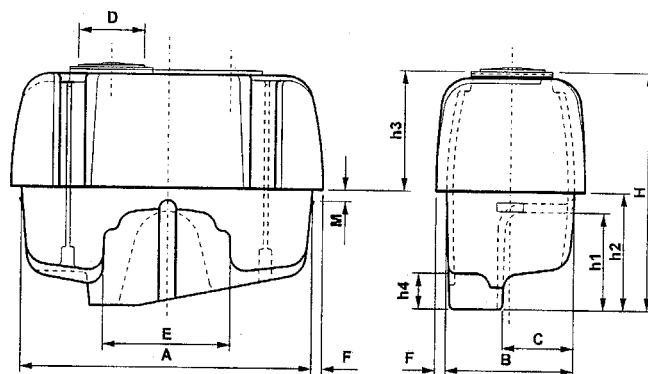

Art.	Cap. lt.	A	B	C	E	F	H	h ₁	h ₂	h ₃	h ₄	M	D
1511	300	1050	510	310	450	50	890	345	480	410	120	50	310
1512	400	1050	510	310	450	50	1050	345	480	570	120	50	310
1513	500	1360	600	330	600	50	950	440	520	430	140	50	310
1514	600	1360	600	330	600	50	1030	440	520	510	140	50	310

La serie POLYPRISMA è intercambiabile con la serie PRISMA in vetroresina fino alla capacità lt. 600.

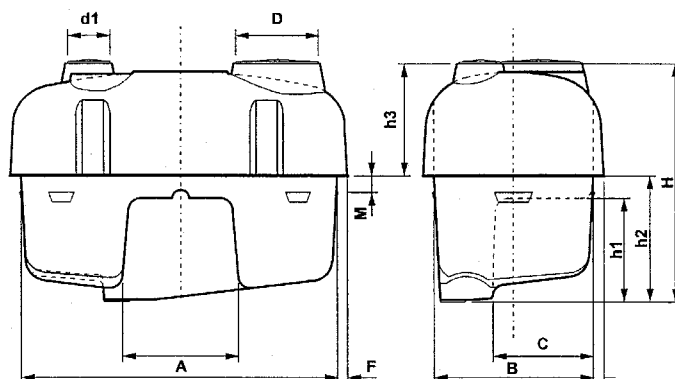

Art.	Cap. lt.	A	B	C	E	F	H	h ₁	h ₂	h ₃	M	D	d ₁
1515	800	1490	740	450	600	50	1070	470	580	490	80	415	210
1516	1000	1490	740	450	600	50	1215	470	580	635	80	415	210
1517	1250	1490	740	450	600	50	1455	470	580	875	80	415	210

CON COPERCHIO Ø 210 SUPPLEMENTARE

SERIE POLIPRISMA AT



AUTOPORTANTI PER ATOMIZZATORI E GRUPPI PORTATI

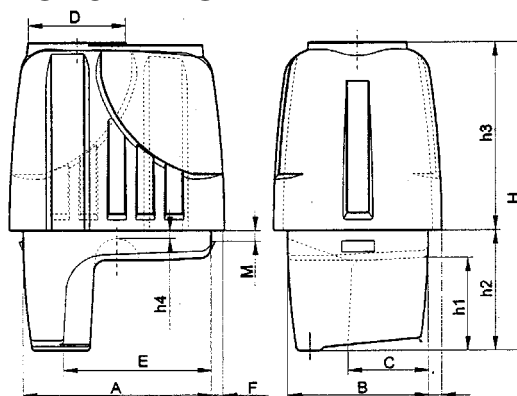

Art.	Cap. Lt.	A	B	C	E	H	h ₁	h ₂	h ₃	h ₄	F	M	D
1506	200	690	515	295	543	875	345	445	430	40	50	40	310
1507	300	690	515	296	543	1140	345	445	695	40	50	40	310
1508	400	810	515	310	605	1305	370	600	705	40	50	40	310
1560	400	950	515	310	670	1160	330	600	560	40	50	40	310

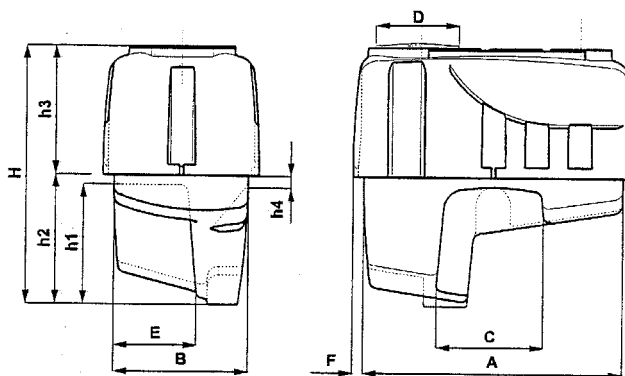

Art.	Cap. Lt.	A	B	C	E	H	h ₁	h ₂	h ₃	h ₄	D
1566	600	1200	620	495	390	1220	565	610	610	40	415



AUTOPORTANTI A SVUOTAMENTO CENTRALE CON FORO PASSAGGIO CARDANO

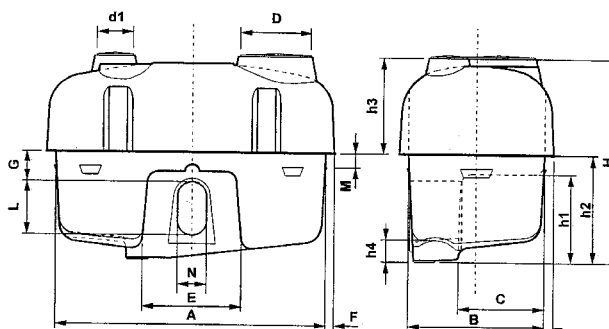

Art.	Cap. Lt.	A	B	C	E	F	G	L	N	H	h ₁	h ₂	h ₃	h ₄	M	D	D ₁
1509	800	1490	740	450	600	50	170	300	160	1070	470	580	490	130	80	410	210
1510	1000	1490	740	450	600	50	170	300	160	1215	470	580	635	130	80	410	210

SERIE POLIGOOD CEV

CENTINATE ELLITTICHE VERTICALI

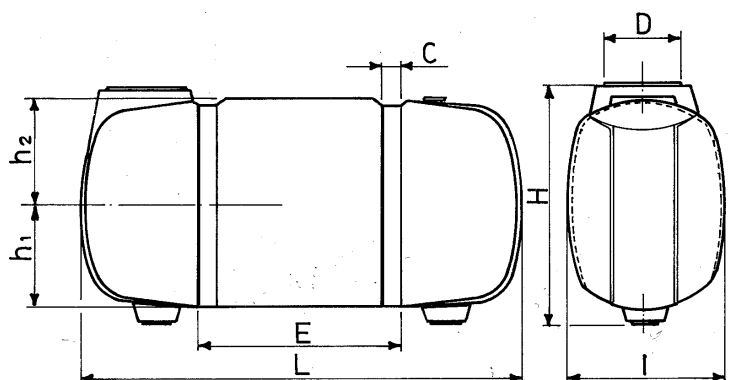

Art.	Cap. Lit.	L	I	H	E	C	h ₁	h ₂	D
1536	600	1700	640	910	780	80	410	420	310
1537	800	1700	640	1100	780	80	505	515	310
1538	1000	1700	640	1580	780	80	985	515	310

SERIE POLIGOOD PL



RETTANGOLARI PER PIANALI

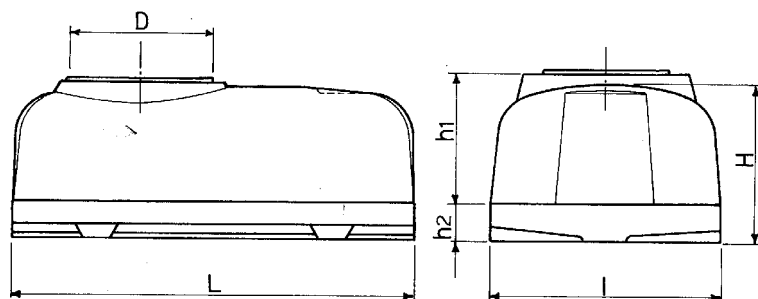

Art.	Cap. Lit.	L	I	H	h ₁	h ₂	D
1539	300	1340	745	460	395	105	310
1540	400	1340	745	560	505	105	310
1541	600*	1590	840	620	490	160	410
1542	800*	1590	840	765	635	160	410
1567	1000						

* PL 600/800 montano un coperchio filettato Ø 210 supplementare

SERIE EUROCOMPACT 3P

AUTOPORTANTI A SVUOTAMENTO CENTRALE,
CON CISTERNE LAVAMANI E LAVAIMPIANTO

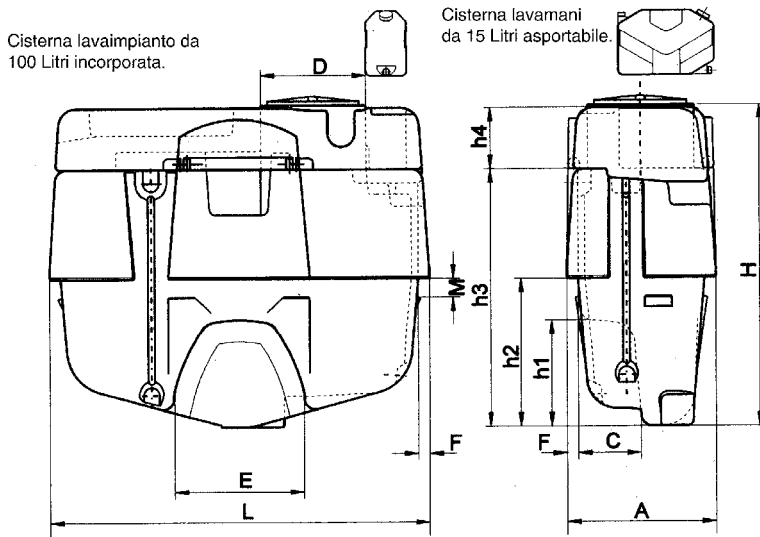

Art.	Cap. lt.	L	A	C	D	E	F	h ₁	h ₂	h ₃	h ₄	H	M
1558	800	1700	660	280	415	570	50	450	650	1130	270	1400	80
1559	1000	1700	660	280	415	570	50	450	650	1310	270	1580	80

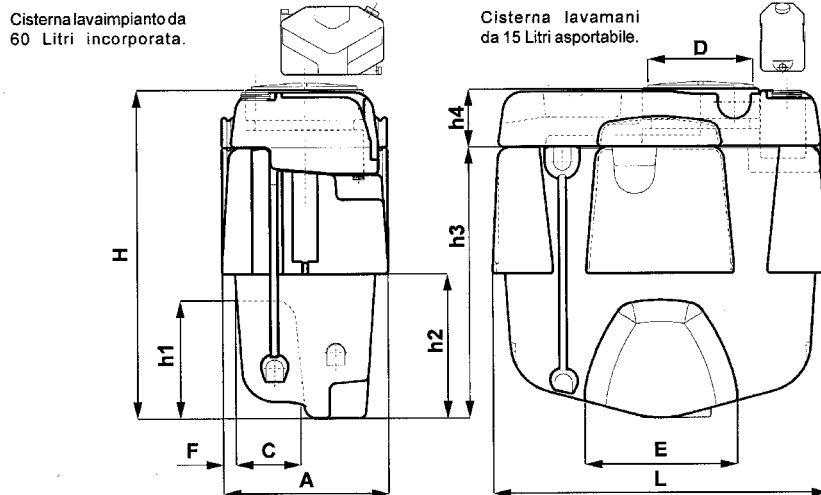

Art.	Cap. lt.	L	A	C	D	E	F	h ₁	h ₂	h ₃	h ₄	H
1556	400											
1557	600	1340	660	330	415	620	50	450	580	1090	230	1320

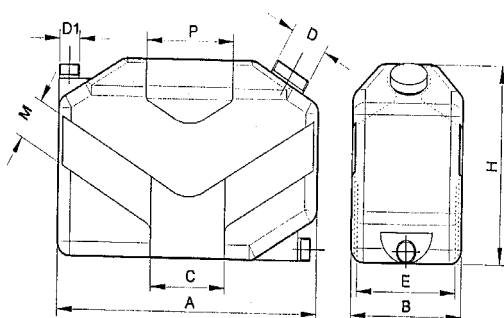

EURO 3P 15

Art.	Cap. lt.	A	B	C	D
1563	15	420	170	120	600
D ₁	E	H	M	P	
32	140	270	60	140	

SERIE POLYMARTE 300

AUTOPORTANTE CENTINATA

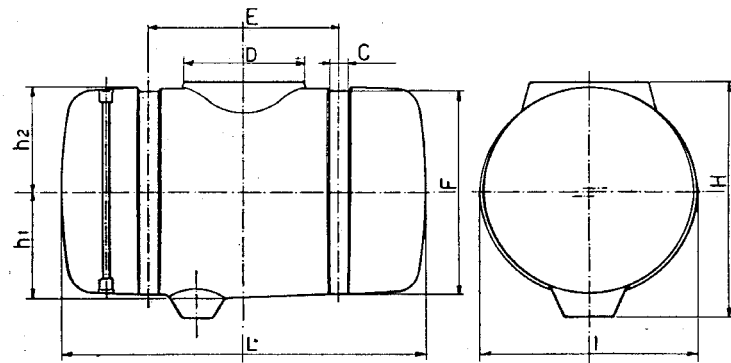

Art.	Cap. lt.	L	I	H	E	C	F	h_1	h_2	D
1501	300	1100	655	710	570	60	610	315	315	310

SERIE EUROPRISMA

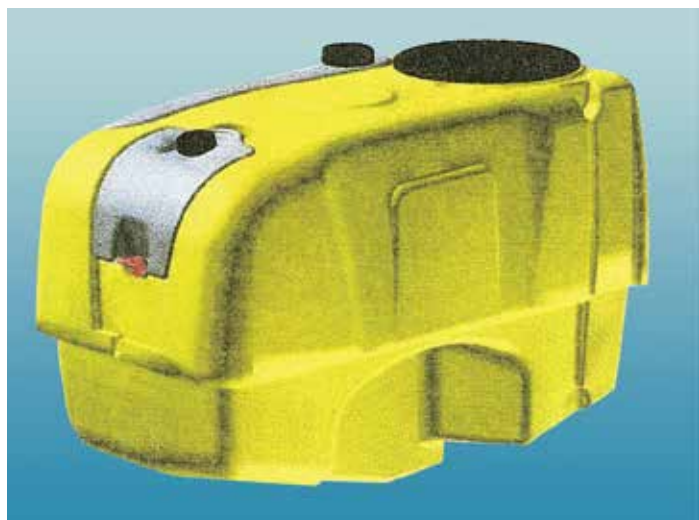

AUTOPORTANTI PER GRUPPI
PORTATI DA DISERBO CON SERBATOIO
LAVAIMPIANTO E LAVAMANI
INCORPORATI

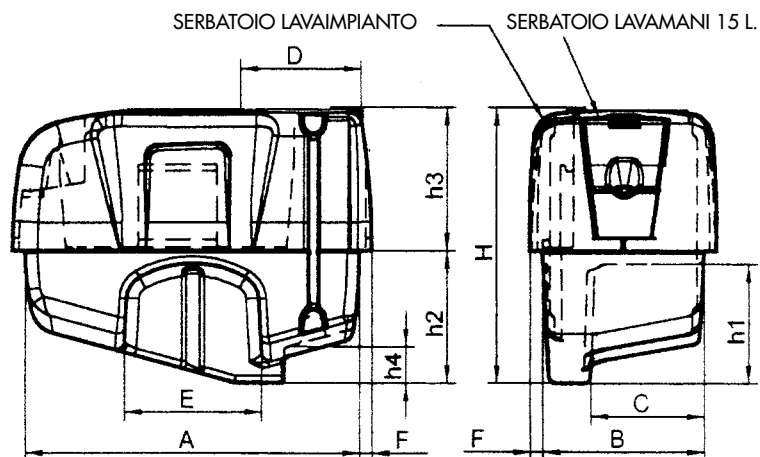

Art.	Cap. lt.	A	B	C	D	E	F	H	h ₁	h ₂	h ₃	h ₄
1576	400	1050	530	380	415	445	50	1090	430	510	580	130
1578	600	1350	650	450	415	550	50	1075	470	520	555	140
1579	800	1350	650	450	415	550	50	1275	470	520	755	140

SERIE EUROPRISMA AT

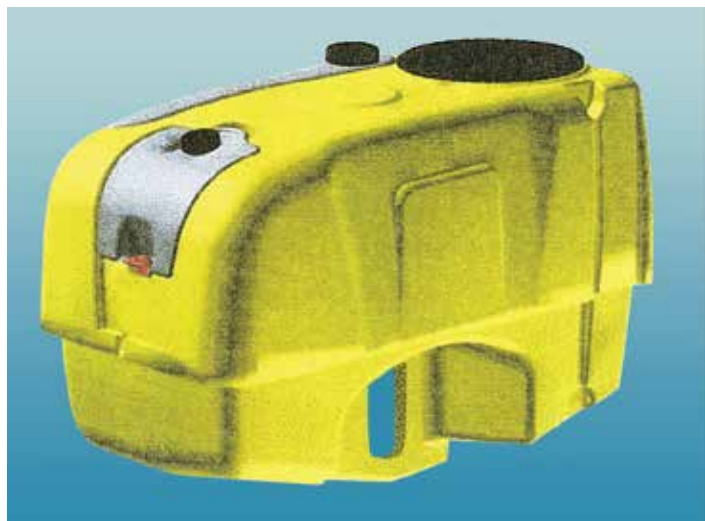

AUTOPORTANTI PER GRUPPI PORTATI
DA ATOMIZZATORE CON SERBATOIO
LAVAIMPIANTO E LAVAMANI
INCORPORATI

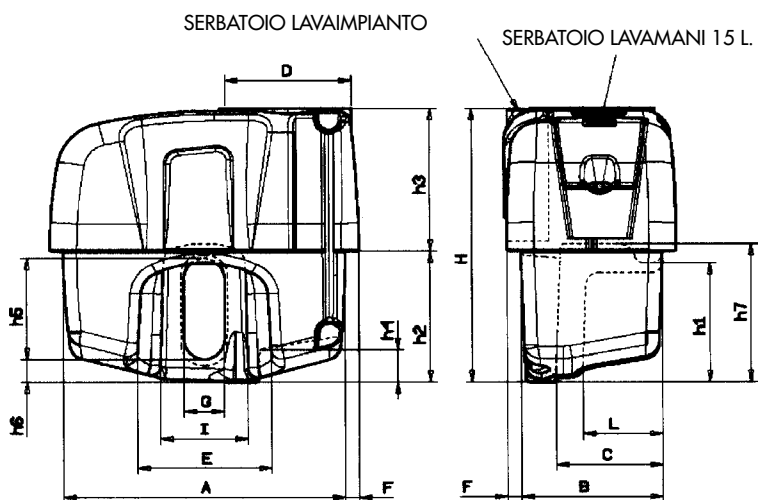

Art.	Cap. lt.	A	B	C	D	E	F	H	h ₁	h ₂	h ₃	h ₄
1584	400	1050	530	380	415	445	50	1090	430	510	580	130
1585	600	1350	650	450	415	550	50	1075	470	520	555	140
1586	800	1350	650	450	415	550	50	1275	470	520	755	140

LAVAIMPIANTO PER SERIE EUROPRISMA - EUROPRISMA AT

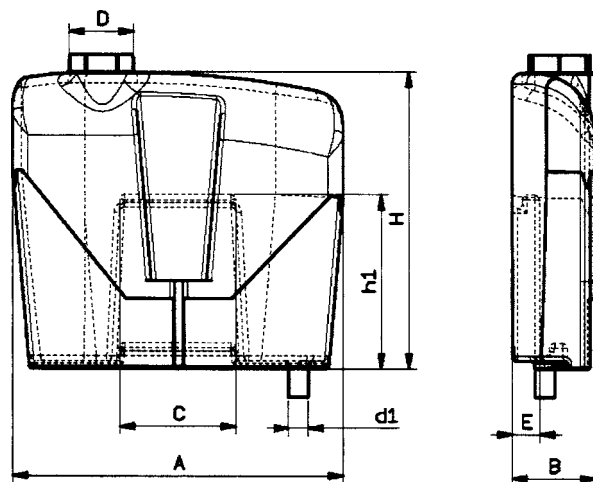
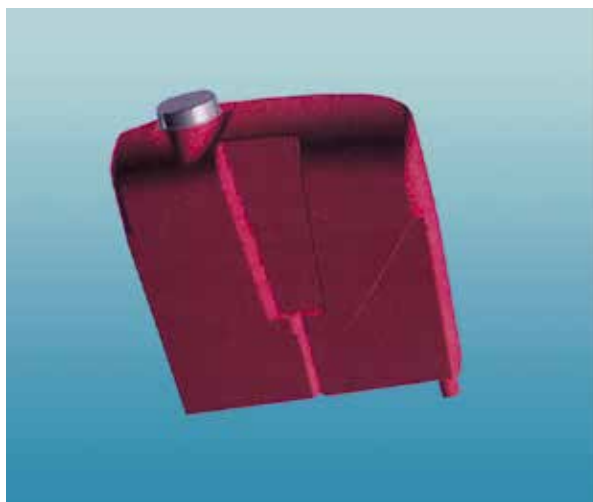

Art.	Cap. Lit.	A	B	C	E	H	h ₁	D	D ₁
1580	40	660	165	230	55	570	335	120	1" 1/4
1582	60	940	190	430	65	540	345	120	1" 1/4

LAVAMANI PER SERIE EUROPRISMA - EUROPRISMA AT

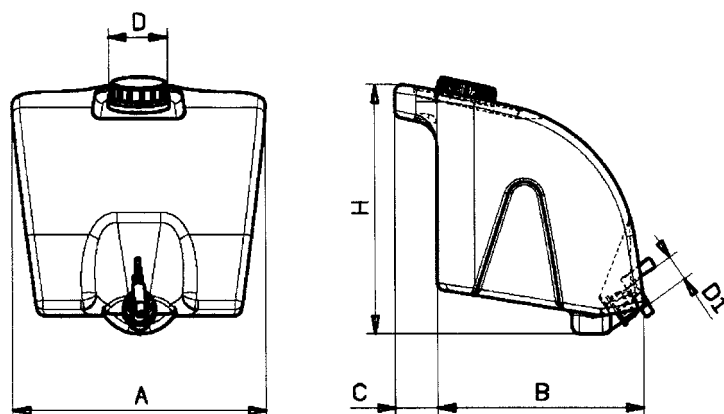
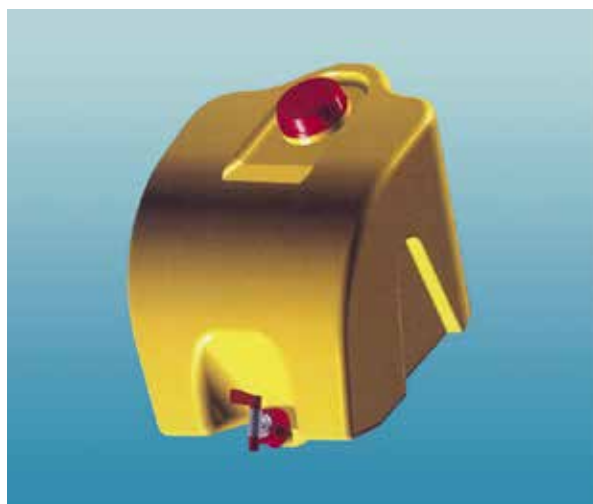

Art.	Cap. Lit.	A	B	C	E	H	h ₁	D	D ₁
1583	15	330	270	55		315		80	32



Tankmastes Serbatoi s.r.l.

41057 SPILAMBERTO (MO) - Via dei Marmorari, 2
Tel. 059/78.32.04 - Fax: 059/78.40.09
www.tankmasters.it - info@tankmasters.com